

The **ALPHA** is provided with a mechanical locking system that grants the operator locking in the opened and closed position avoiding any needs for electric locks and/or magnetic locks. The torque intensity and the anti-crushing safety are adjustable through the control board.

ALPHA PLUS is provided with mechanical limit switches which are located and protected in aluminum housing. It is also provided with a manual releasing system by a lever Key-locked that must be used only in case of emergency and/or power failure to manually operate the gate.

MAIN PARTS

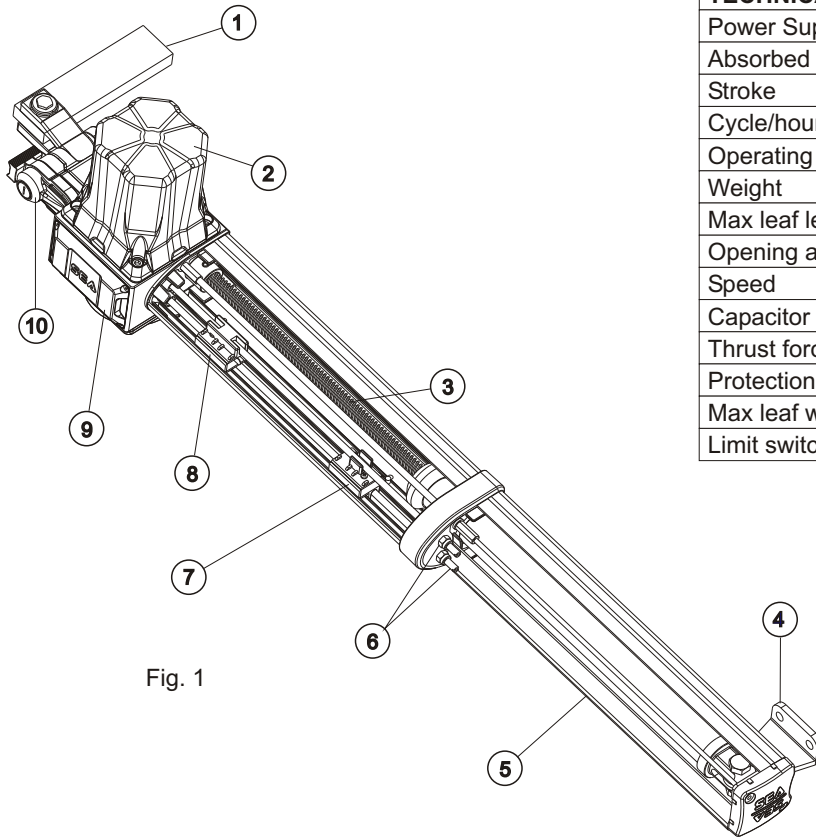

Fig. 1

TECHNICAL FEATURES	Alpha 550 230V	Alpha 550 24V
Power Supply	230Vac (±5%) 50/60 Hz	
Absorbed current	300W	70W
Stroke	550 mm	
Cycle/hour	20	40
Operating temperature	-20°C +55°C	
Weight	11 Kg	
Max leaf length	5,5 m	
Opening angle	90° - 120°	
Speed	1,7 cm/sec.	
Capacitor	8 uF	-
Thrust force	350 daN	170 daN
Protection class	IP54	
Max leaf weight	500 Kg	
Limit switch	yes	

- 1 Back bracket
- 2 Electric motor
- 3 Endless screw
- 4 Front bracket
- 5 Aluminum shaft-cover
- 6 Limit switches adjusting screws
- 7 Micro-switch for limit switch
- 8 Micro-switch for limit switch
- 9 Capacitor housing (230V version)
- 10 Manual Releasing lever

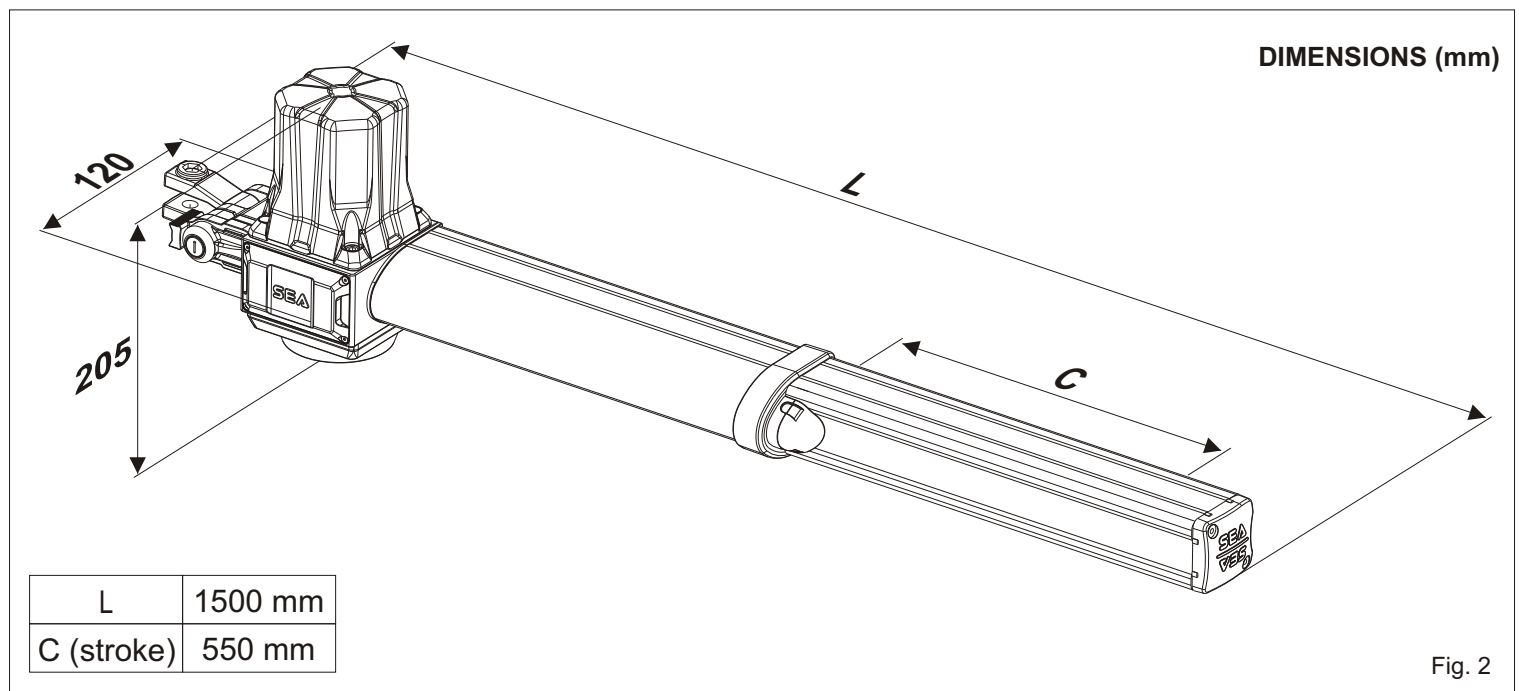

Fig. 2



SEA®

Sistemi Elettronici
di Apertura Porte e Cancelli
International registered trademark n. 804888

ALPHA 550 PLUS



ENGLISH

DIAGRAM FOR THE USE OF ALPHA 550

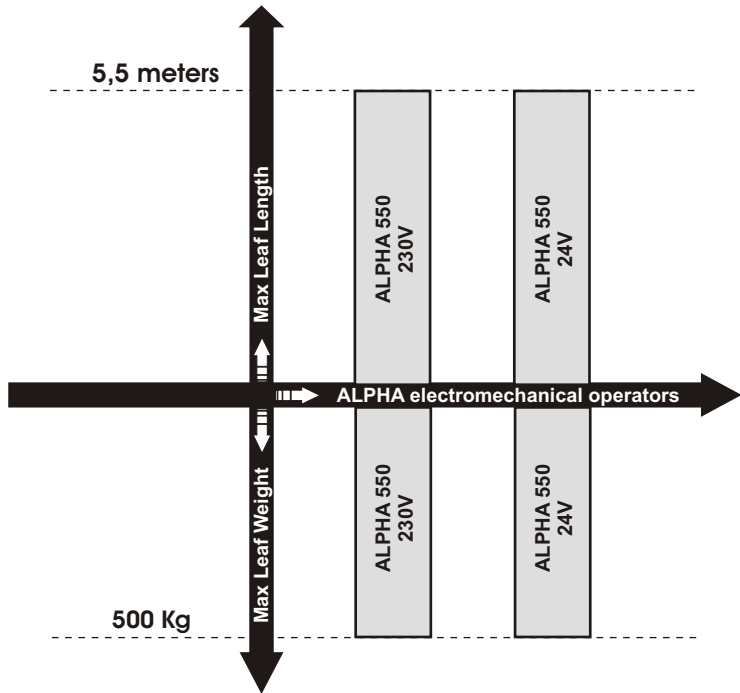

Notice:

The operator must be installed with the motor facing upward (Fig. 3)

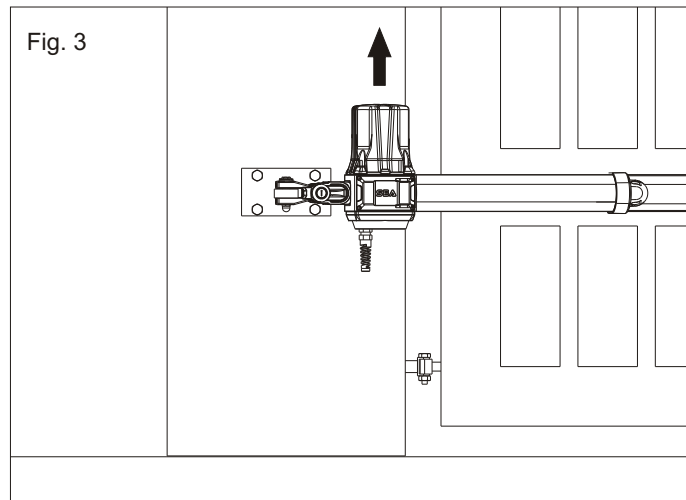

STANDARD INSTALLATION

- 1) Operator
- 2) Warning Plate
- 3) Electronic Unit
- 4) Warning Lamp
- 5) Tx Photocell
- 6) Differential switch 16A 0,03A
- 7) Rx Photocell
- 8) Key Switch
- 9) Radio Receiver
- 10) Antenna
- 11) Column for photocells
- 12) Mechanical Stop

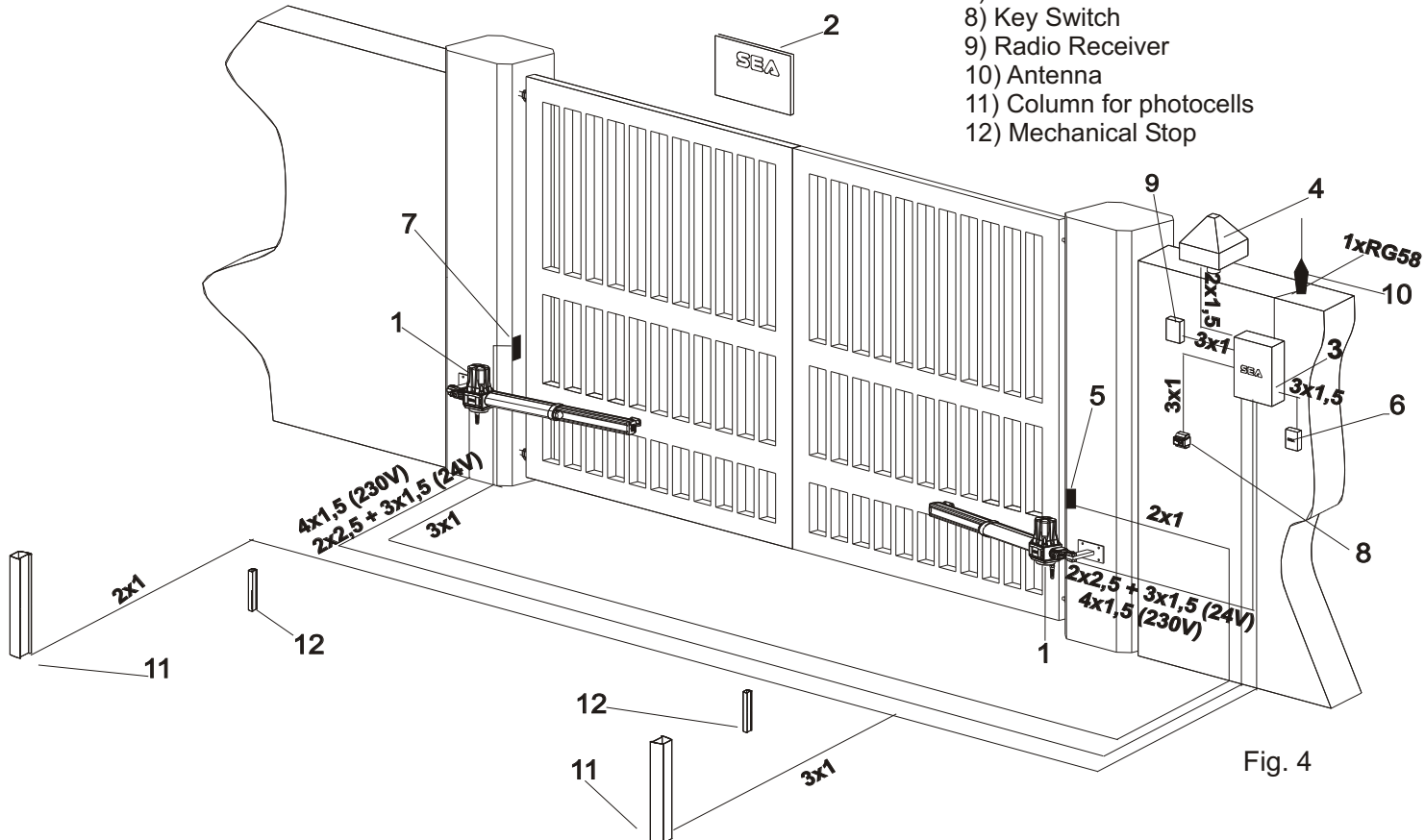

1. GATE ARRANGEMENT

It is necessary to make controls on the gate to make sure the application of ALPHA automation can be possible.

Make sure that:

- A.** the gate fixed and moving parts have a strong and crush-proof structure;
- B.** the length of each leaf is not over 5,5 meters;
- C.** the weight of each leaf is not over 500 Kg;
- D.** the hinges are hardly anchored and are able to support the torque of the operator; they do not have irregular movements and/or any friction during the whole movement of the leaf;

2. INSTALLATION OF THE OPERATORS

2.1. Fix the holed mounting plate to the post using screws as shown in Fig 5. The plate must be positioned perfectly horizontal and perpendicular to the post,

2.2. Weld the back bracket to the plate (Fig 6) following the dimensions shown in Fig 7 and 8. If it is necessary, cut the bracket without going over the minimum limit of 60 mm (Fig 9).

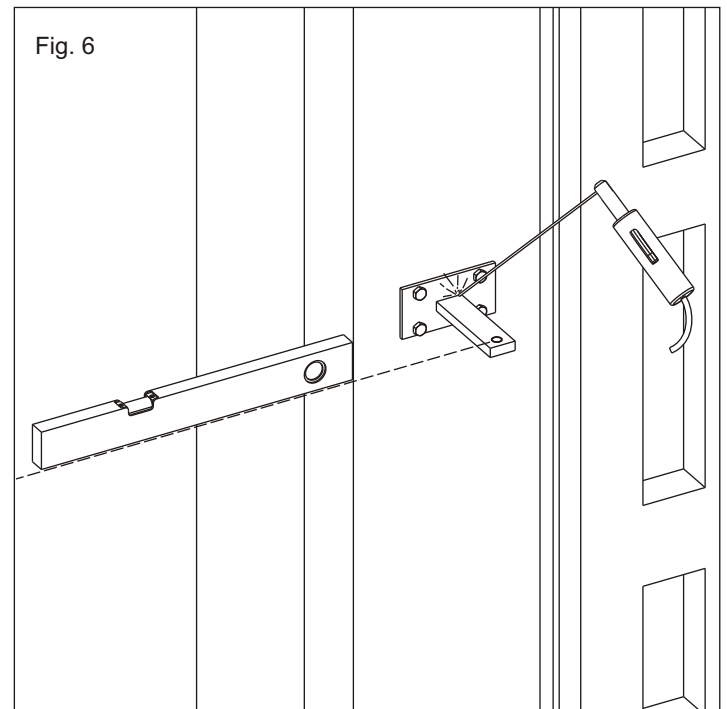
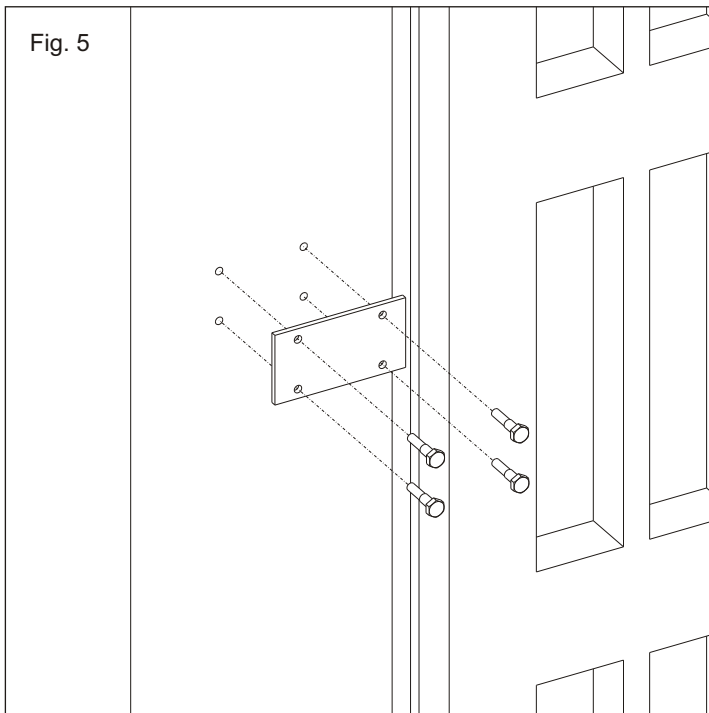

NOTICE:
ALPHA operator is not provided with mechanical torque regulation. The control board must be provided with electronic torque regulation (unless presence detectors are installed) to install it in conformity with the DIRETTIVA EN12453 and EN12445.

DIMENSIONS FOR INSTALLATION

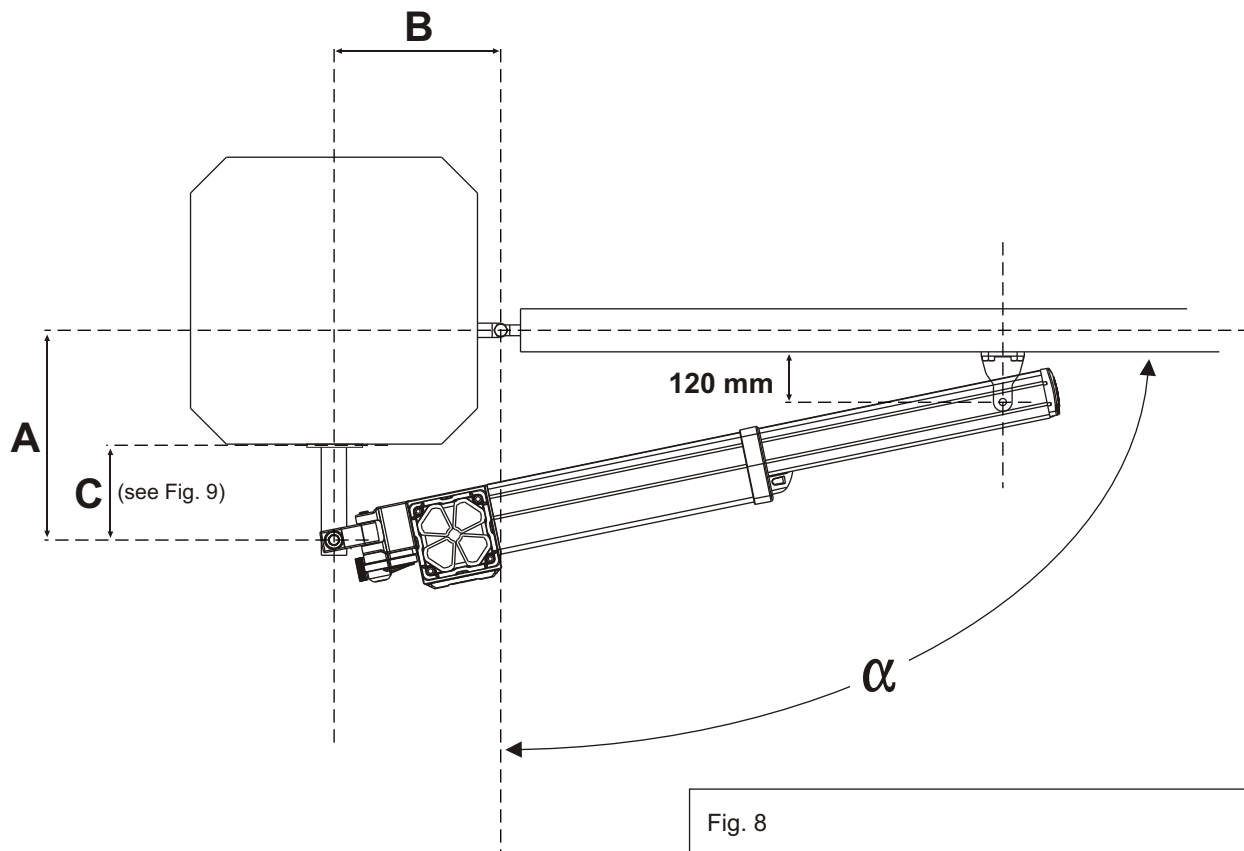

Fig. 7

ALPHA 550 PLUS

Opening angle α				
90°	A	310	290	270
	B	220	240	260
120°	A	260		
	B	250		

The above mentioned dimensions are in mm.

During selection, prefer the higher dimensions of A and B.

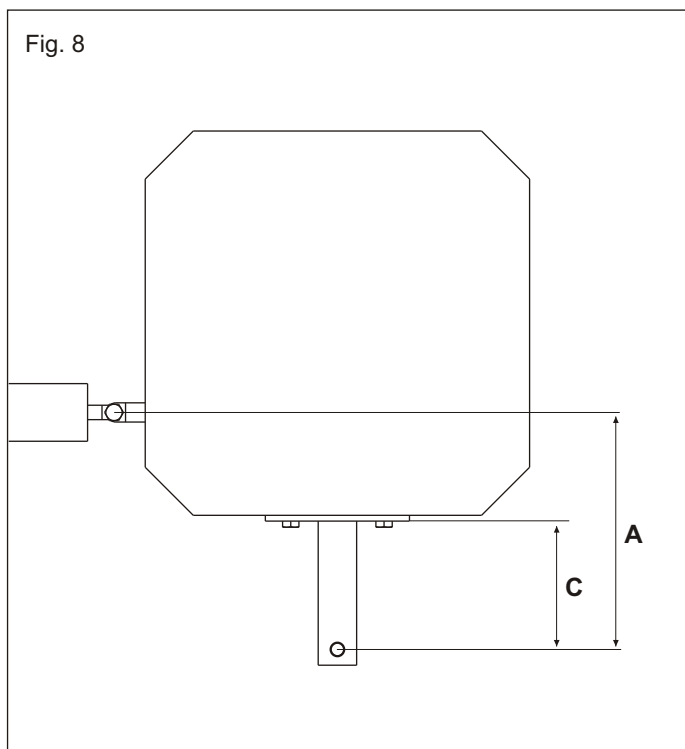

Fig. 8

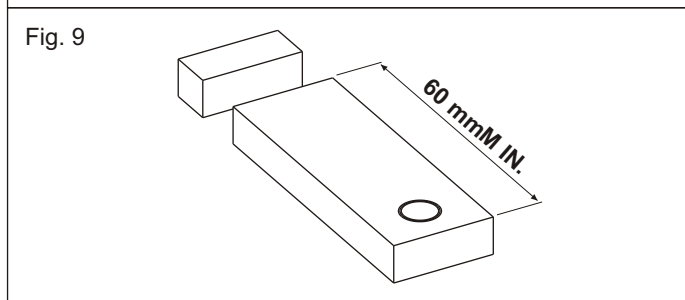
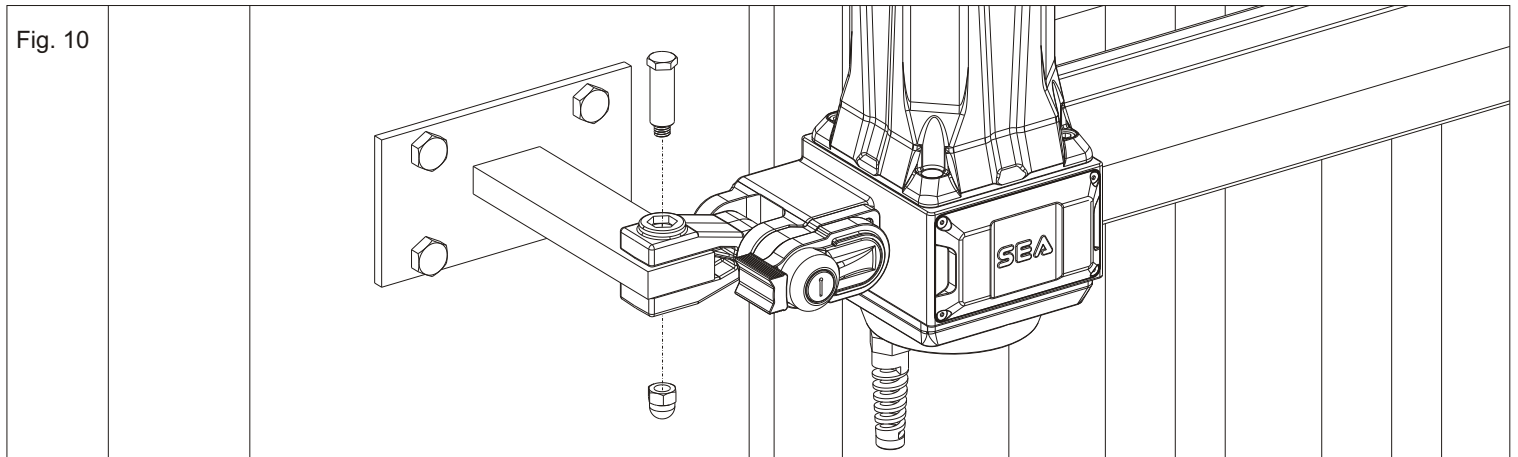

Fig. 9

2.3. Attach the operator on the previously installed back-bracket and fix it with the provided pivot (Fig 10)



2.4. Release the arm (see paragraph 3)

2.5. WARNING: Turn the shaft up to its max. extension, afterwards turn it about at least half turn into the opposite direction (screw it) see Fig. 11 and 12.

Note: After installation, in opening, leave minimum 15 mm of working stroke, to avoid that the operator goes into mechanical lock (if necessary install the stops on the ground or the optional special mechanical stops for Alpha).

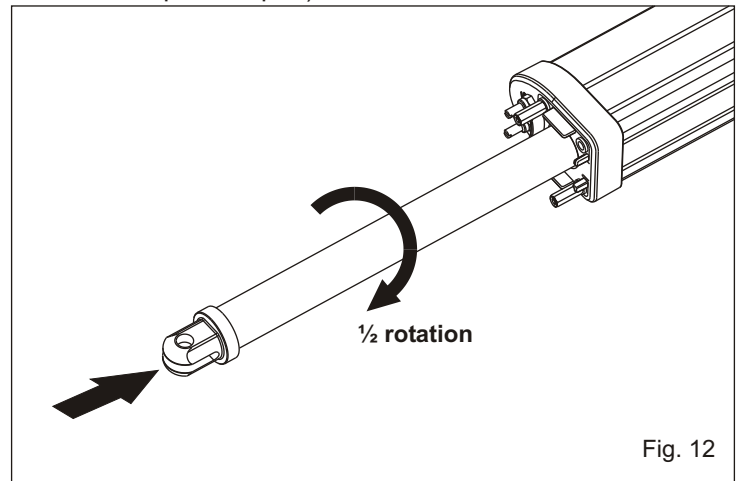
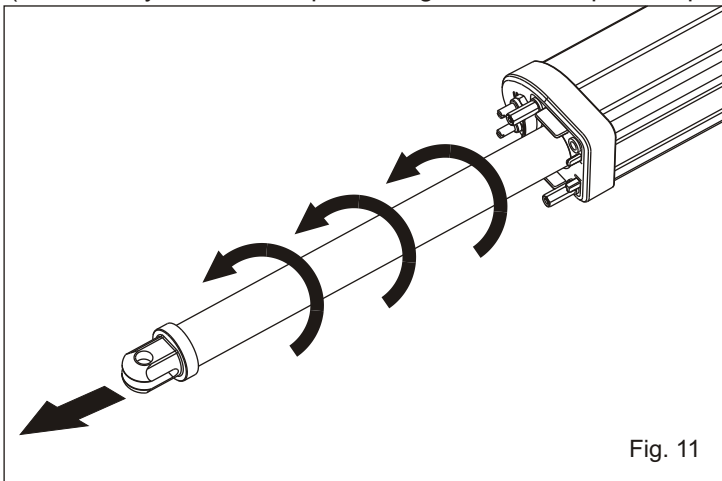

2.6. Attach the front bracket to the extremity of the shaft (Fig 13)

2.7. Close the gate

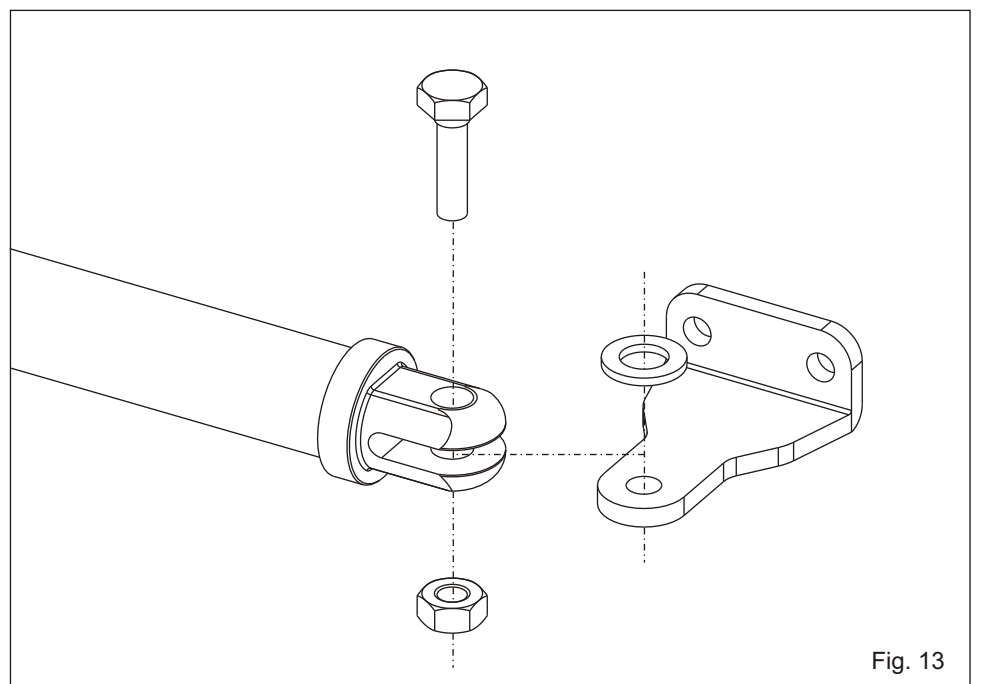



2.8. Drill a hole into the gate (Fig 14) to be able to attach the front bracket with the supplied bolts being careful to place the operator perfectly horizontal (Fig 15).

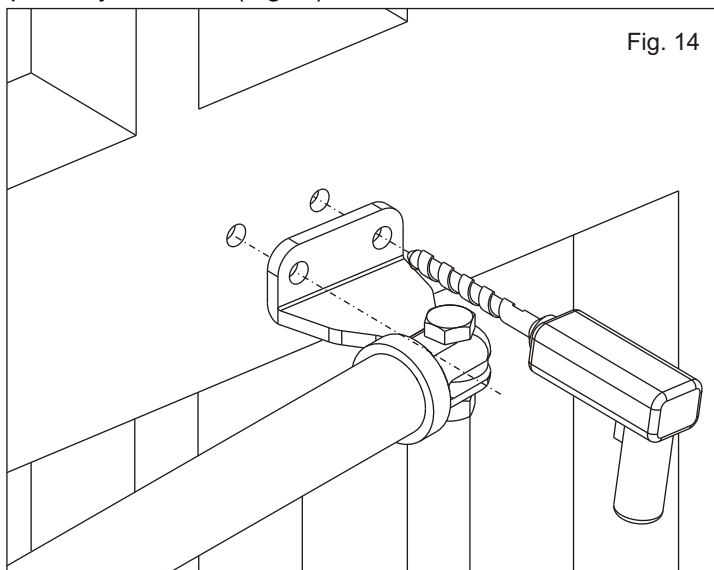

Fig. 14

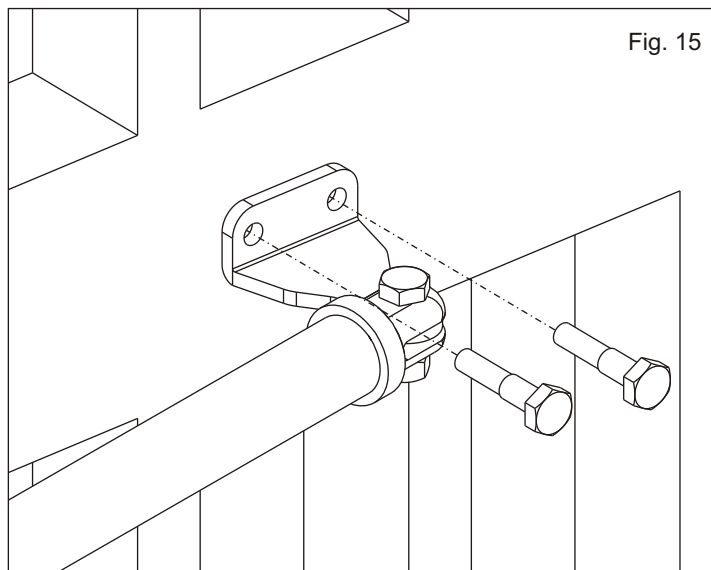

Fig. 15

NOTE:

if it is not possible to attach the front bracket with the bolts, weld it to the gate (Fig 16), being careful to protect the shaft from welding waste.

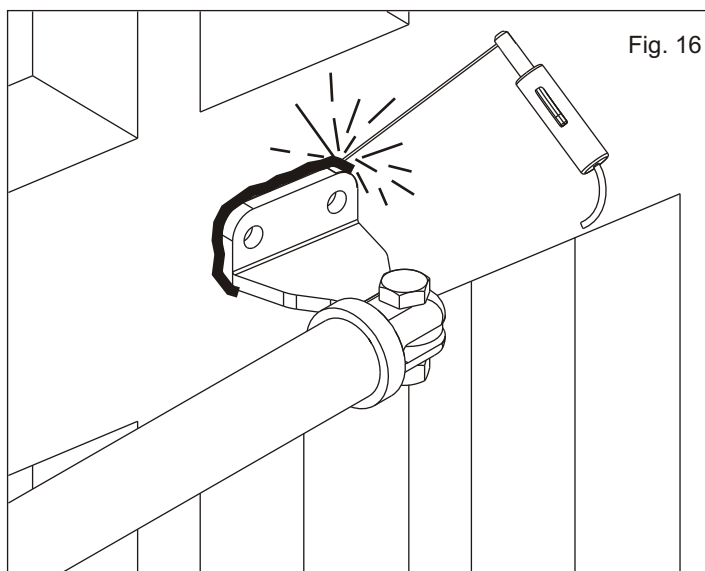

Fig. 16

INSTALLATION OF POSITIVE STOPS

On request mechanical stop in opening and closing available.

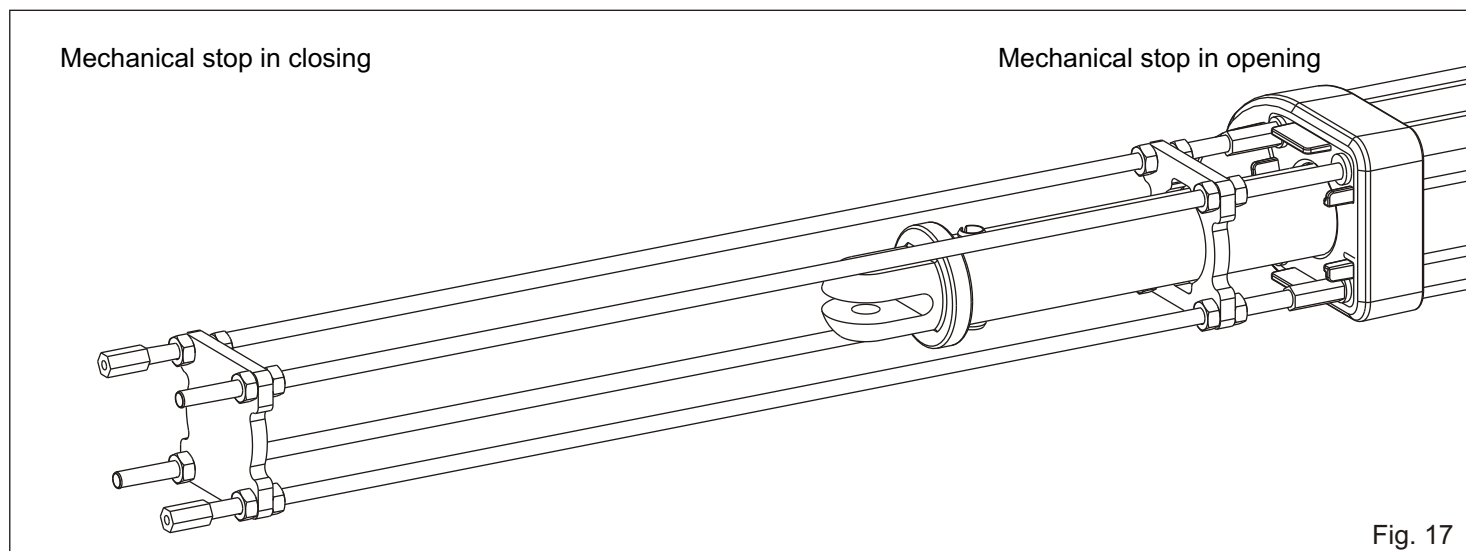

Fig. 17



SEA[®]

Sistemi Elettronici
di Apertura Porte e Cancelli
International registered trademark n. 804888

ALPHA 550 PLUS

CE

ENGLISH

ALPHA PLUS 230V CONNEXIONS

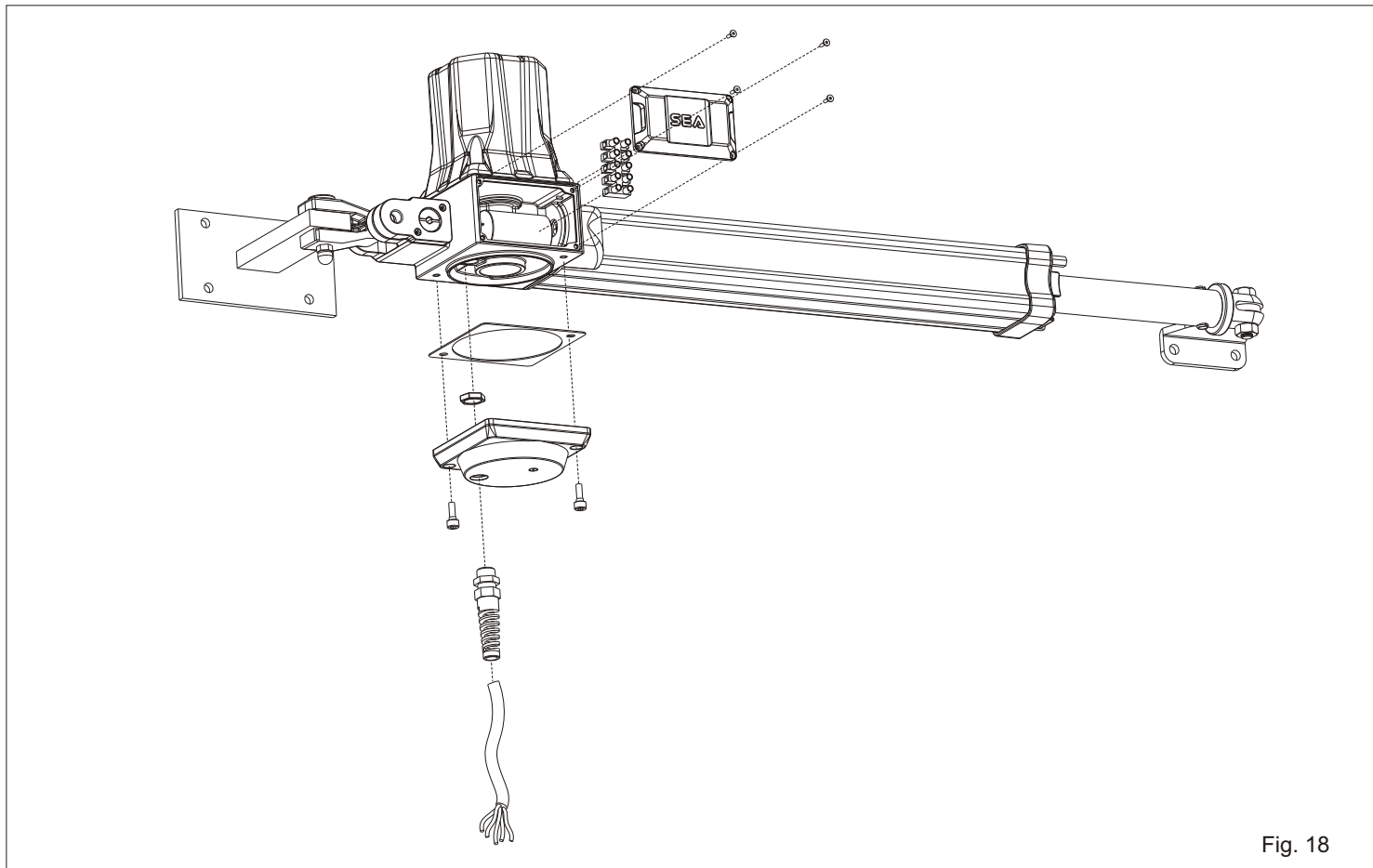

Fig. 18

RIGHT

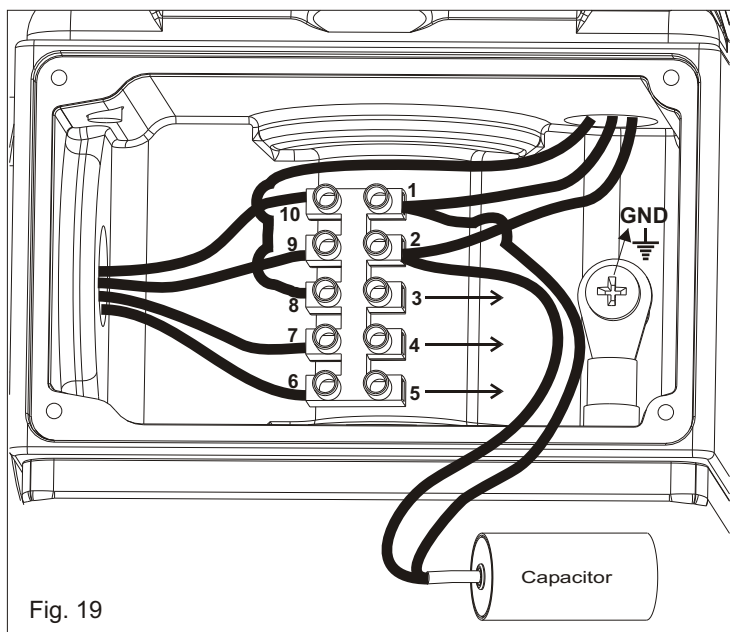

Fig. 19

- 1= Motor+Capacitor - *Brown*
- 2= Motor+Capacitor - *Black*
- 3= Common - *Blue*
- 4= *Brown*
- 5= *Black*
- 6, 10= Limit switch - *Brown*
- 7, 9= Limit switch - *Black*
- 8= Motor - *Blue*

LEFT

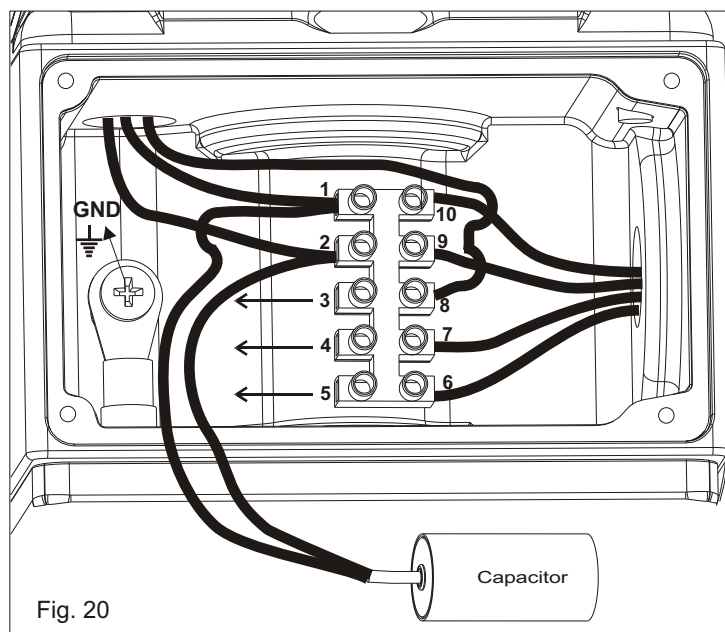

Fig. 20

- 1= Motor+Capacitor - *Black*
- 2= Motor+Capacitor - *Brown*
- 3= Common - *Blu*
- 4= *Nero*
- 5= *Marrone*
- 6, 10= Limit switch - *Brown*
- 7, 9= Limit switch - *Black*
- 8= Motor - *Blue*



SEA®

Sistemi Elettronici
di Apertura Porte e Cancelli
International registered trademark n. 804888

ALPHA 550 PLUS



ENGLISH

ALPHA 24V CONNEXIONS

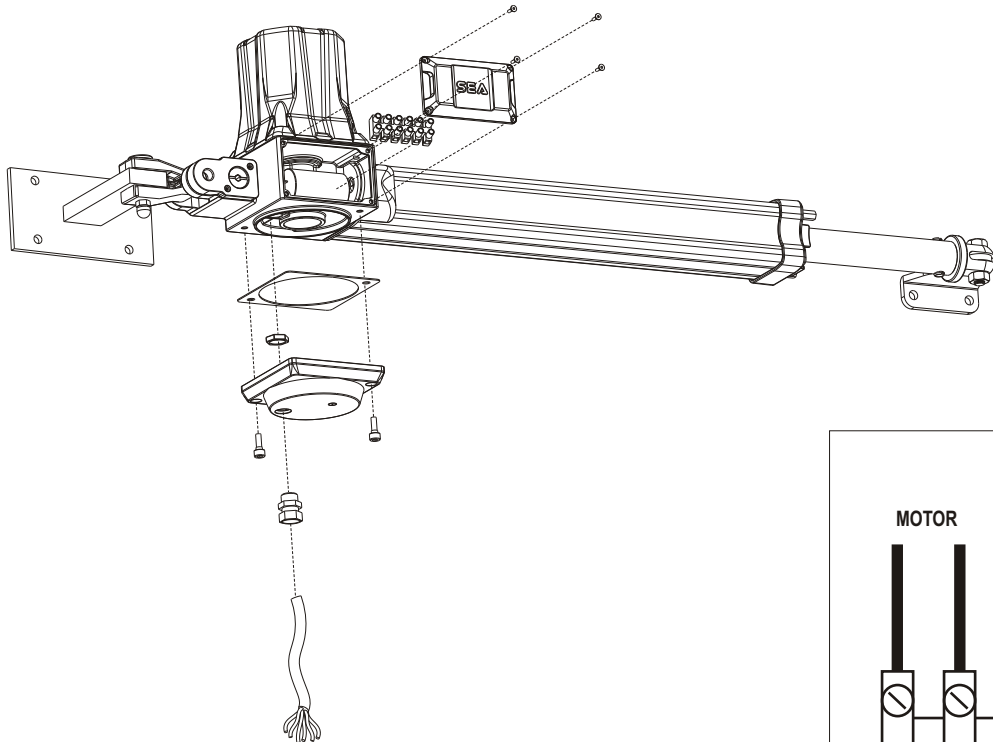

- 1, 2= Motor
- 3, 4= Limit switch opening - Black
- 5, 6= Limit switch closing - Brown

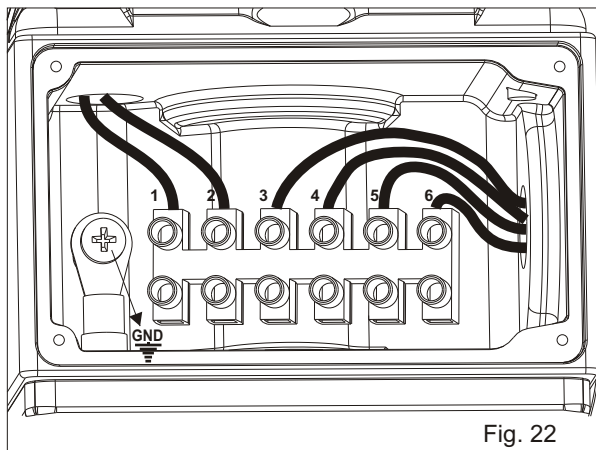

Fig. 21

Fig. 22

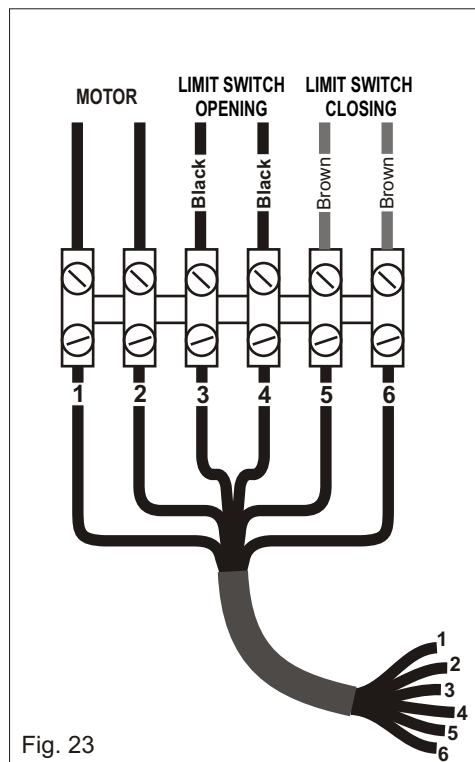

Fig. 23

2.9. Release the arm (see paragraph 3)

2.10. Remove the pull tongue from the shaft-cover (Fig 24) and mount it on the operator through the two tie-rods without excessively tightening the two cover-nuts (Fig 25).

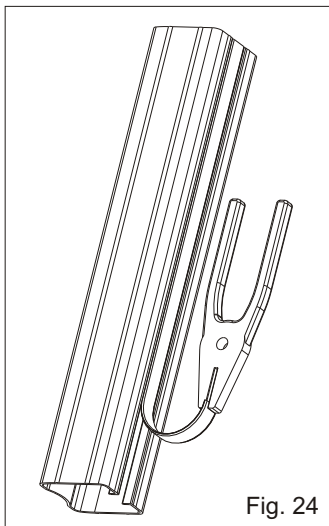

Fig. 24

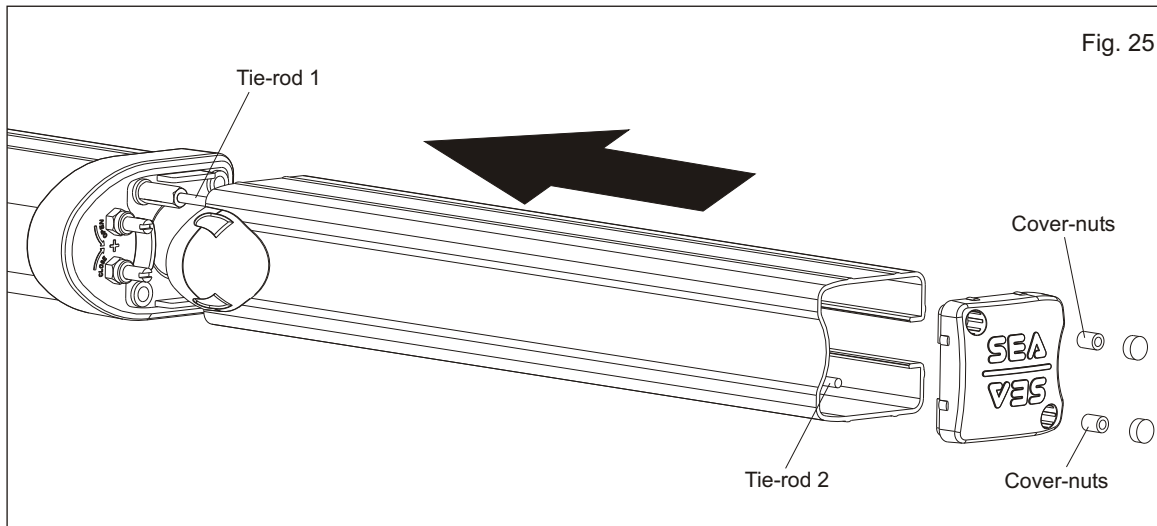
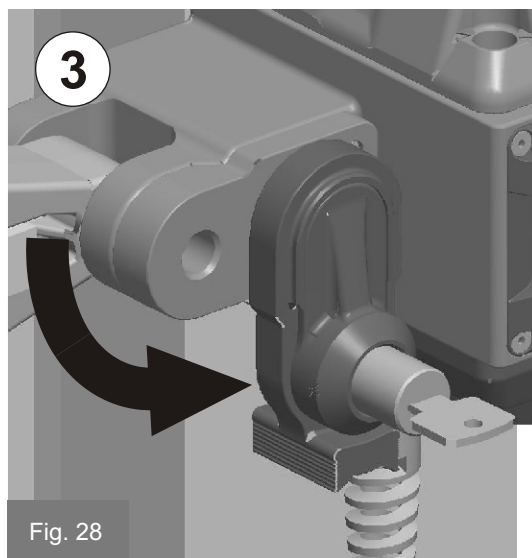
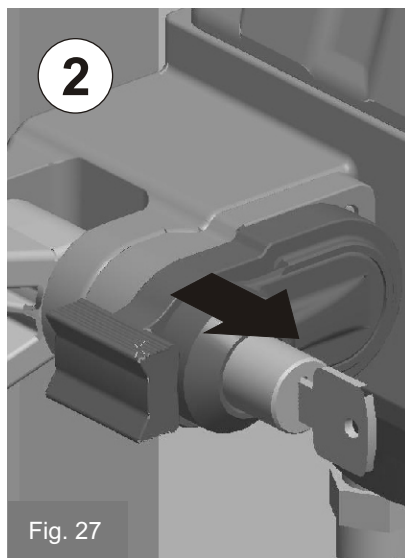
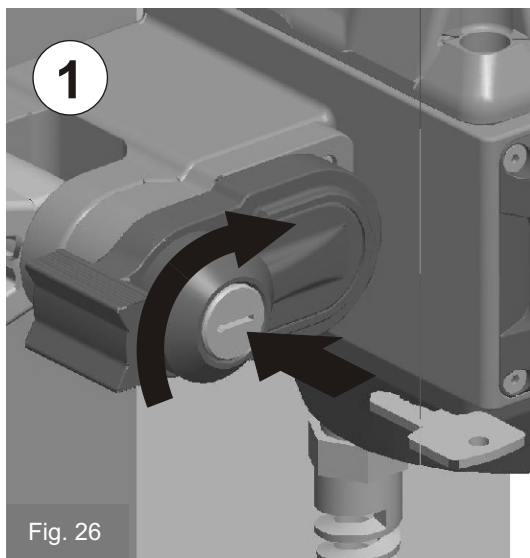

Fig. 25

3. RELEASING SYSTEM OF THE OPERATOR

3.1. To release the operator follow the instruction below

1. Insert the key in lock and turn it 90° to the right as on Fig. 26
2. be sure that the lock cylinder is completely out (Fig. 27).
3. Turn the releasing lever towards the bottom as (Fig. 28).



3.2. To lock back the operator take back the lever to the position as (Fig. 26), turn the key pushing the cylinder back in and move the gate leaf until you hear the operator gears to hook-up.

4. LIMIT SWITCHES ADJUSTMENTS

4.1. Remove the pastic cover as shown below. (Fig. 29)

4.2. Use a screw-driver to rotate the screw (Fig. 30 and 31) knowing that rotating each screw toward the (+) it will increase the stroke in opening (OPEN) and in closing(CLOSE).

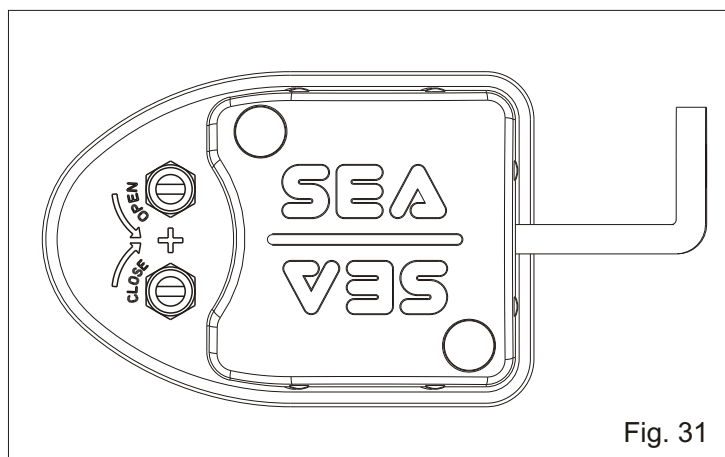
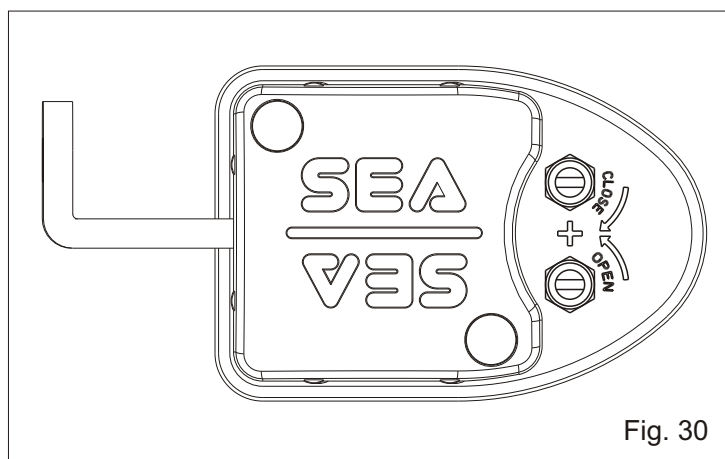
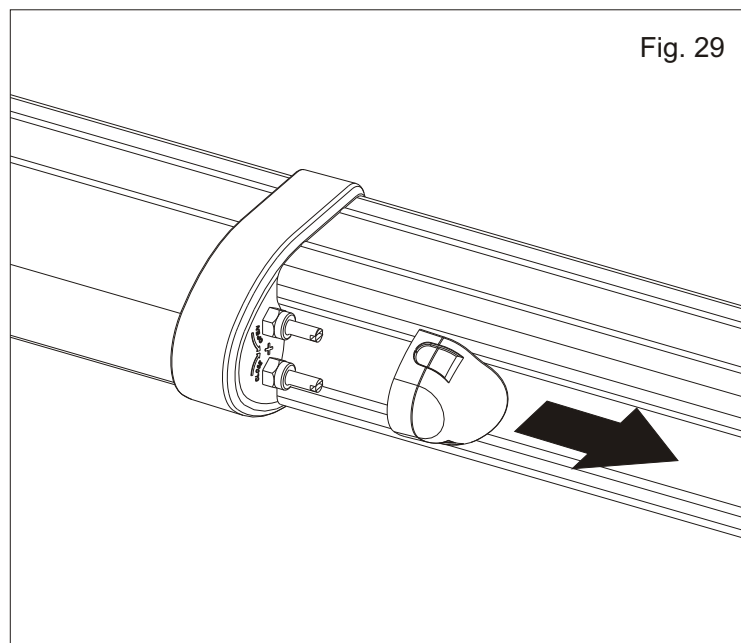

RISK EXAMINATION

The points pointed by arrows in Fig. 32 are potentially dangerous. The installer must take a thorough risk examination to prevent crushing, conveying, cutting, grappling, trapping so as to guarantee a safe installation for people, things and animals (Re. Laws in force in the country where installation has been made.).

Fig. 32

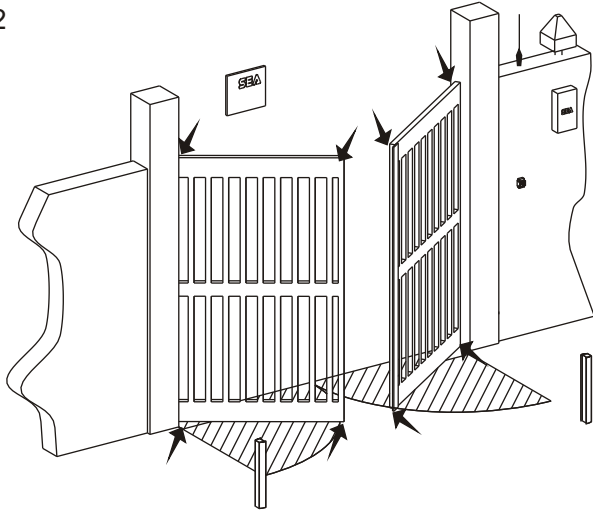

NOTICE

SEA s.r.l can not be deemed responsible for any damage or accident caused by product breaking, being damages or accidents due to a failure to comply with the instructions herein. The guarantee will be void and the manufacturer responsibility (according to Machine Law) will be nullified if SEA Srl original spare parts are not being used.

The electrical installation shall be carried out by a professional technician who will release documentation as requested by the laws in force. This is a quotation from the GENERAL DIRECTIONS that the installer must read carefully before installing.

Packaging materials such as plastic bags, foam polystyrene, nails etc must be kept out of children's reach as dangers may arise.

DECLARATION OF CONFORMITY

SEA declares under its responsibility that the products
ALPHA 550

meets the essential requisites provided for by the following European Directive and following changes:

89/392/CEE (Machine Directive)

89/336/CEE (Electromagnetic Compatibility Directive)

73/23/CEE (Low Tension Directive)

SAFETY PRECAUTIONS:

All electrical work should conform to current regulations. A 16 A 0,030 A differential switch must be incorporated into the source of the operators main electrical supply and the entire system properly earth bonded. Always run mains carrying cables in separate ducts to low voltage control cables to prevent mains interference.

INTENDED USE:

Alpha operator has been designed to be used only for the automation of swing gates.

SPARE PARTS:

To obtain spare parts contact:

SEA S.r.l. - Zona Ind.le S.Atto, 64020 S. Nicolò a Tordino - Teramo - ITALIA

SAFETY AND ENVIRONMENTAL COMPATIBILITY:

Don't waste product packing materials and/or circuits.

When being transported this product must be properly packaged and handled with care.

MAINTENANCE AND OUT OF SERVICE:

The decommission and maintenance of this unit must only be carried out by specialised and authorised personnel.

NOTE: THE MANUFACTURER CAN NOT BE DEEMED RESPONSIBLE FOR ANY DAMAGE OR INJURY CAUSED BY IMPROPER USE OF THIS PRODUCT.

SEA reserves the right to do changes or variations that may be necessary to its products with no obligation to notice.

TERMS OF SALE

EFFICACY OF THE FOLLOWING TERMS OF SALE: The following general terms of sale shall be applied to all orders sent to SEA srl. All sales made by SEA to all customers are made under the prescription of this terms of sales which are integral part of the sale contract and cancel and substitute all opposed clauses or specific negotiations present in the order or in other documents received from the buyer.

GENERAL NOTICE The gate automation systems must be assembled exclusively with SEA components, unless specific agreements apply. Non-compliance with the applicable safety standards (European Standards EN 12453 EN12445 and others) and with good installation practice releases SEA from any responsibilities. SEA shall not be held responsible for any failure to execute a correct and safe installation under the above mentioned standards.

1) PROPOSED ORDER The proposed order shall be accepted only prior SEA approval of it. By signing the proposed order, the Buyer shall be bound to enter a purchase agreement, according to the specifications stated in the proposed order and always under those Terms of sale. On the other hand, failure to notify the Buyer of said approval must not be construed as automatic acceptance on the part of SEA.

2) PERIOD OF THE OFFER The offer proposed by SEA or by its branch sales department shall be valid for 30 solar days, unless otherwise notified.

3) PRICING The prices in the proposed order are quoted from the Price List which is valid on the date the order was issued. The discounts granted by the branch sales department of SEA shall apply only prior to acceptance on the part of SEA. The prices are for merchandise delivered ex-works from the SEA establishment in Teramo, not including VAT and special packaging. SEA reserves the right to change at any time this price list, providing timely notice to the sales network.

4) PAYMENTS The accepted forms of payment are each time notified or approved by SEA. The interest rate on delay in payment shall be 1.5% every month but anyway shall not be higher than the max. interest rate legally permitted.

5) DELIVERY Delivery shall take place, approximately and not peremptorily, within 30 working days from the date of receipt of the order, unless otherwise notified. Transport of the goods sold shall be at Buyer's cost and risk. SEA shall not bear the costs of delivery giving the goods to the carrier, as chosen either by SEA or by the Buyer. Any loss and/or damage of the goods during transport, are at Buyer's cost.

6) COMPLAINTS Any complaints and/or claims shall be sent to SEA within 8 solar days from receipt of the goods, proved by adequate supporting documents as to their truthfulness.

7) SUPPLY The concerning order will be accepted by SEA without any engagement and subordinately to the possibility to get its supplies of raw material which is necessary for the production; Eventual completely or partially unsuccessful executions cannot be reason for complains or reservations for damage. SEA supply is strictly limited to the goods of its manufacturing, not including assembly, installation and testing. SEA, therefore, disclaims any responsibility for damage deriving, also to third parties, from noncompliance of safety standards and good practice during installation and use of the purchased products.

8) WARRANTY.

SILVER: The mechanical components of the operators belonging to this line are guaranteed for 24 months from the date of manufacturing written on the operator.

GOLD: The mechanical components of the operators belonging to this line are guaranteed for 36 months from the date of manufacturing written on the operator.

PLATINUM: The mechanical components of the operators belonging to this line are guaranteed for 36 months from the date of manufacturing written on the operator. The base warranty (36 months) will be extended for further 24 months (up to a total of 60 months) when it is acquired the certificate of warranty which will be filled in and sent to SEA s.r.l. within 30 days from the purchase date. The electronic devices and the systems of command are guaranteed for 24 months from the date of manufacturing. In case of defective product, SEA undertakes to replace free of charge or to repair the goods provided that they are returned to SEA repair centre.

The definition of warranty status is by unquestionable assessment of SEA. The replaced parts shall remain propriety of SEA. Binding upon the parties, the material held in warranty by the Buyer, must be sent back to SEA repair centre with fees prepaid, and shall be dispatched by SEA with carriage forward. The warranty shall not cover any required labour activities. The recognized defects, whatever their nature, shall not produce any responsibility and/or damage claim on the part of the Buyer against SEA. The guarantee is in no case recognized if changes are made to the goods, or in the case of improper use, or in the case of tampering or improper installation, or if the product label of the manufacturer with the registered SEA trademark n° 804888 has been removed. Furthermore, the warranty shall not apply if SEA products are partly or completely coupled with non-original mechanical and/or electronic components, and in particular, without a specific relevant authorization, and if the Buyer is not making regular payments. The warranty shall not cover damage caused by transport, expendable material, faults due to non-conformity with performance specifications of the products shown in the price list. No indemnification is granted during repairing and/or replacing of the goods in warranty. SEA disclaims any responsibility for damage to objects and persons deriving from non-compliance with safety standards, installation instructions or use of sold goods. The repairs of products in warranty and out of warranty is accepted only if the procedure of SEA are fully respected by the customer.

9) RESERVED DOMAIN A clause of reserved domain applies to the sold goods; SEA shall decide autonomously whether to make use of it or not, whereby the Buyer acquires the property of the goods only after full payment of the invoice.

10) COMPETENT COURT OF LAW In case of disputes arising from the application of the agreement, the competent court of law is the tribunal of Teramo. The official language for the interpretation of the catalogue, the manuals, the terms of sale and any other is the italian language. SEA reserves the faculty to make technical changes to improve its own products, which are and are not included in this price list at any moment and without notice.

SEA declines any responsibility due to possible mistakes contained inside the present price list caused by printing and/or copying. The present price list cancels and substitutes the previous ones. The Buyer, according to the law No. 196/2003 (privacy code) consents to put his personal data, deriving from the present contract, in SEA archives and electronic files, and he also gives his consent to their treatment for commercial and administrative purposes.

Industrial ownership rights: with the purchase, the buyer accepts in full the present Terms of Sale and recognizes that SEA has the exclusive legal ownership of the registered SEA International trademark n° 804888 which is attached on each products label, and/or on manuals, packaging and/or in any other documentation, and he will commit himself to use it in its marketing and/or installation activity in a way which does not reduce the value of these rights; he won't also remove, replace or modify the trademark or any other particularity from the products. Any kind of replication or use of SEA brand is forbidden as well as of any change of sings-brands on the products, unless preventive and expressed authorization by SEA.